

E912 20AMP BATTERY CHARGER 12V – 24V

Sensed Switching Point: 13V

12V – 24V BATTERY CHARGER 20AMP

Charge a 24V Battery from a 12V Battery System

HIGH SPECIFICATION

MANUFACTURED IN THE UK

- PART NO: E912
- TYPE: SWITCH MODE STEP UP BATTERY CHARGER
- CHARGING CURRENT: 20 AMP
- INPUT VOLTAGE: 11 – 15V DC
- OUTPUT VOLTAGE: 28V DC
- OVERLOAD PROTECTION: EXTERNAL FUSE
- POLARITY PROTECTED: EXTERNAL FUSE
- HIGH TEMP PROTECTED: YES
- SHORT CIRCUIT PROTECTION: EXTERNAL FUSE
- EFFICIENCY: > 85%
- DIMENSIONS: 215mm X 100mm X 75mm
- FIXING CENTRES: 200mm X 70mm (4 HOLE FIXING)
- HOLE SIZE: 4.5mm
- WEIGHT: 1150g
- CONSTRUCTION: ANODISED COOLING PROFILE



MODELS ALSO AVAILABLE: 10AMP / 30AMP / 40AMP

OEM AND TRADE ENQUIRIES WELCOME

WHY NOT VISIT OUR WEBSITES TO VIEW THE OTHER PRODUCTS WE MANUFACTURE:

<http://www.battery-management-voltage-converter.com>

This site covers our:

- Battery Management Systems
- Split Charge Controllers
- DC-DC Battery Chargers
- DC-DC Voltage Converters
- Trailer Voltage Converters
- Battery Status Indicators
- Voltage Sensitive Switches.

<http://www.eurogroup-gb.com>

This site covers our Range of:

- Water Level Monitors
- Water Level Probes
- Temperature Monitors
- Temperature Probes
- Air Conditioning Fan Control Units
- Vehicle Flashers and Interrupters
- Light Control Units
- Oil Level Monitors
- Oil Level Probes
- Hydraulic Control Units
- Audible Warning Devices
- Reversing Alarms
- Timers
- Vehicle Safety and Security Units
- Digital Speed Switches
- Solenoid Controllers
- Relays, Connectors, Lamps, Switches
- Earth Straps
- Looms and Wiring Harnesses
- Transformer and Coil Winding
- Mechanical Assembly
- Special Purpose Electrical / Electronic Assembly
- Encapsulation and Formal Coating
- Vacuum Formed Parts
- Printed Circuit Board Assembly

EURO MANUFACTURING AND MARKETING LIMITED

Euro Works, 11-13 High Street, Wem, Shropshire SY4 5AA, England.

Tel: +44 (0) 1939 235073

Fax: +44 (0) 1939 235074

Email: sales@eurogroup-gb.com OR sales@battery-management-voltage-converter.com

Web Site: www.eurogroup-gb.com OR www.battery-management-voltage-converter.com

BEFORE INSTALLATION YOU NEED TO PURCHASE:

- 1 X 20A AUTOMOTIVE BLADE FUSE
- 1 X 50A AUTOMOTIVE BLADE FUSE
- 1 X 1A AUTOMOTIVE BLADE FUSE
- 3 X INLINE FUSE HOLDER (TO TAKE BLADE FUSES)

RECOMMENDED MINIMUM CABLES SIZES:

- INPUT (RED): 10mm² CONDUCTOR CROSS SECTION (80/0.4mm)
- OUTPUT (BLUE): 10mm² CONDUCTOR CROSS SECTION (80/0.4mm)
- GROUND (BLACK): 10mm² CONDUCTOR CROSS SECTION (80/0.4mm)

The Charger starts when the voltage reaches 13V.

This Battery Charger allows you to charge a 24V Battery from a 12V Battery System.

The Battery Charger can be wired in 2 ways:

Wired as a fully automatic Charger

The Brown Control Wire is wired directly to the +ve Connection of the 12V Cranking (Donor) Battery to switch the Charger on and off automatically. In this case the Control Wire senses the 12V Cranking (Donor) Battery Voltage and switches the Charger on only when the 12V Cranking (Donor) Battery is being charged.

The Unit automatically controls the maximum charge into the 24V Leisure (Recipient) Battery preventing it from becoming over-charged / damaged and prevents the 12V Cranking Battery (Donor Battery) from becoming flat / exhausted.

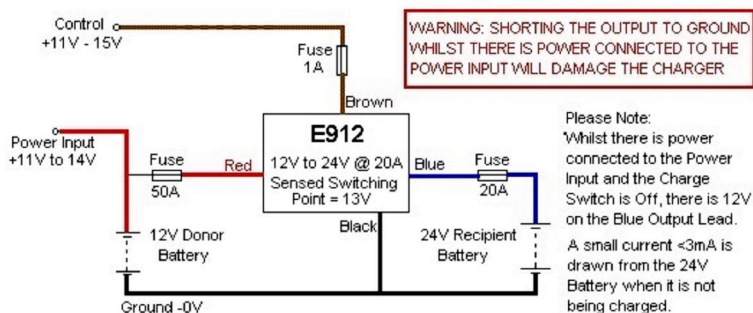

Wired as a manually operated Charger

The Brown Control Wire is wired via a Switch to the +ve Connection of the 12V Cranking (Donor) Battery to switch the Charger on and off manually. In this case the Operator can control when the Battery Charger is switched on or off.

If left on, the Unit will automatically control the maximum charge into the 24V Leisure (Recipient) Battery preventing it from becoming over-charged / damaged and prevent the 12V Cranking Battery (Donor Battery) from becoming flat / exhausted.

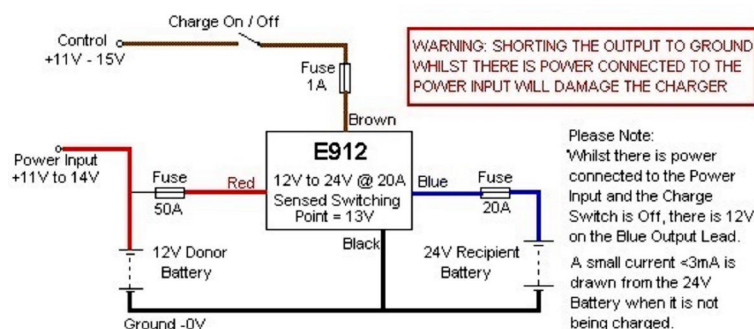

INSTALLATION INSTRUCTIONS:

1. CONNECT THE BLUE LEAD CONNECTION TO THE +VE CONNECTION OF THE 24V LEISURE / AUXILIARY BATTERY (FITTING 1 X INLINE FUSE HOLDER WITH 20A BLADE FUSE BETWEEN THE 24V BATTERY AND THE BATTERY CHARGER AS SHOWN ON WIRING DIAGRAM SUPPLIED WITH UNIT)
2. CONNECT THE BLACK LEAD CONNECTION TO GROUND, IE: THE VEHICLE CHASSIS (COMMON NEGATIVE)
3. CONNECT THE RED LEAD CONNECTION TO THE +VE CONNECTION OF THE 12V CRANKING BATTERY (FITTING 1 X INLINE FUSE HOLDER WITH 50A BLADE FUSE BETWEEN THE 12V BATTERY AND THE BATTERY CHARGER AS SHOWN ON WIRING DIAGRAM SUPPLIED WITH UNIT)
4. THE BROWN CONTROL LEAD CONNECTION GIVES YOU THE OPTION TO SWITCH THE BATTERY CHARGER ON AND OFF USING A STANDARD LOW CURRENT SWITCH.
5. ALTERNATIVELY YOU CAN CONNECT THE BROWN LEAD TO THE +VE CONNECTION OF THE 12V CRANKING / DONOR BATTERY (FITTING 1 X INLINE FUSE HOLDER WITH 1A BLADE FUSE BETWEEN THE 12V BATTERY AND THE BATTERY CHARGER AS SHOWN ON WIRING DIAGRAM SUPPLIED WITH UNIT). THE BROWN LEAD DETECTS THE VOLTAGE OF THE BATTERY AND WHEN THE BATTERY VOLTAGE FALLS BELOW 13V DC IT WILL AUTOMATICALLY SWITCH THE BATTERY CHARGER OFF UNTIL THE ALTERNATOR HAS REPLENISHED / TOPPED UP THE CRANKING / DONOR BATTERY, AT WHICH POINT THE BATTERY CHARGER WILL BE AUTOMATICALLY SWITCHED BACK ON.

IF IN DOUBT, PLEASE CONSULT AN AUTOMOTIVE ELECTRICIAN OR TELEPHONE US ON 01939 235073