

E1144 36AMP BATTERY CHARGER 12V – 12V

12V Turn On

12V – 12V BATTERY CHARGER 36AMP
HIGH SPECIFICATION
MANUFACTURED IN THE UK

- PART NO: E1144
- TYPE: SWITCH MODE BATTERY CHARGER
- Maximum Output (Charging) Current: 36A (PVin = 13V)
- Output Voltage (V-out): 14.0V ± 0.1V
- Power Input Voltage (PVin): 11V to 14V
- Control Input Voltage (CVin): Charger Enabled: >12.1V
- Overload Protection: Yes
- Thermal shutdown: Yes
- Polarity Protection: External Fuses Input = 60A / Output = 45A
- Connections:
 - Red = Positive Input
 - Black = Negative Input, Output and Control
 - Blue = Positive Output
 - Pink = Positive Control
- Physical Dimensions: 330mm X 230mm x 80mm
- Mountings: 4 x Ø 6mm Holes



MODELS ALSO AVAILABLE: 12AMP / 24AMP / 48AMP / 60AMP / 72AMP

WHY NOT VISIT OUR WEBSITES TO VIEW THE OTHER PRODUCTS WE MANUFACTURE:

<http://www.battery-management-voltage-converter.com>

This site covers our:

- Battery Management Systems
- Split Charge Controllers
- DC-DC Battery Chargers
- DC-DC Voltage Converters
- Trailer Voltage Converters
- Battery Status Indicators
- Voltage Sensitive Switches.

<http://www.eurogroup-gb.com>

This site covers our Range of:

- Water Level Monitors
- Water Level Probes
- Temperature Monitors
- Temperature Probes
- Air Conditioning Fan Control Units
- Vehicle Flashers and Interrupters
- Light Control Units
- Oil Level Monitors
- Oil Level Probes
- Hydraulic Control Units
- Audible Warning Devices
- Reversing Alarms
- Timers
- Vehicle Safety and Security Units
- Digital Speed Switches
- Solenoid Controllers
- Relays, Connectors, Lamps, Switches
- Earth Straps
- Looms and Wiring Harnesses
- Transformer and Coil Winding
- Mechanical Assembly
- Special Purpose Electrical / Electronic Assembly
- Encapsulation and Formal Coating
- Vacuum Formed Parts
- Printed Circuit Board Assembly

EURO MANUFACTURING AND MARKETING LIMITED

Euro Works, 11-13 High Street, Wem, Shropshire SY4 5AA, England.

Tel: +44 (0) 1939 235073

Fax: +44 (0) 1939 235074

Email: sales@eurogroup-gb.com OR sales@battery-management-voltage-converter.com

Web Site: www.eurogroup-gb.com OR www.battery-management-voltage-converter.com

BEFORE INSTALLATION YOU NEED TO PURCHASE:

- 1 X 1A AUTOMOTIVE BLADE FUSE (COLOUR: BLACK)
- 1 X INLINE FUSE HOLDER (TO TAKE BLADE FUSES)

RECOMMENDED MINIMUM CABLES SIZES:

- INPUT (RED): 16.0mm² – 25.0mm² CONDUCTOR CROSS SECTION (126/0.40mm – 196/0.40mm)
- OUTPUT (BLUE): 16.0mm² – 25.0mm² CONDUCTOR CROSS SECTION (126/0.40mm – 196/0.40mm)
- GROUND (BLACK): 16.0mm² – 25.0mm² CONDUCTOR CROSS SECTION (126/0.40mm – 196/0.40mm)
- CONTROL (PINK): 1.0mm² CONDUCTOR CROSS SECTION (32/0.2mm)

The Charger starts when the voltage reaches approximately 12V.

This Unit = 3 X E914 12A Battery Chargers wired in parallel to form a single 36A module

Wired as a fully automatic Charger

The Pink Control Wire Connection is wired directly to the +ve Connection of the 12V Cranking (Donor) Battery to switch the Charger on and off automatically.

In this case the Control Wire Connection senses the 12V Cranking (Donor) Battery Voltage and switches the Charger on only when the 12V Cranking (Donor) Battery is being charged. The Unit automatically controls the maximum charge into the 12V Leisure (Recipient) Battery preventing it from becoming over-charged / damaged and prevents the 12V Cranking Battery (Donor Battery) from becoming flat / exhausted.

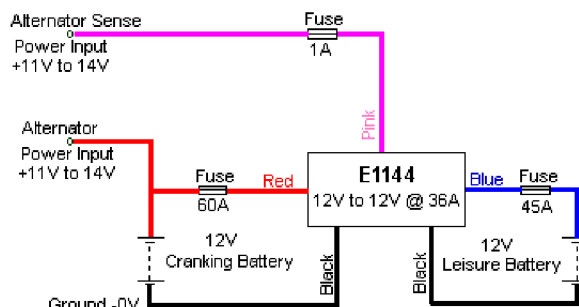

Wired to only operate when the engine is running

The Pink Control Wire connection is wired to any +ve connection which becomes live when the Ignition is switched on. The Unit automatically controls the maximum charge into the 12V Leisure (Recipient) Battery preventing it from becoming over-charged / damaged.

Wired as a manually operated Charger

The Pink Control Wire Connection is wired via a Switch to the +ve Connection of the 12V Cranking (Donor) Battery to switch the Charger on and off manually.

In this case the Operator can control when the Battery Charger is switched on or off.

If left on, the Unit will automatically control the maximum charge into the 12V Leisure (Recipient) Battery preventing it from becoming over-charged / damaged and prevent the 12V Cranking Battery (Donor Battery) from becoming flat / exhausted.

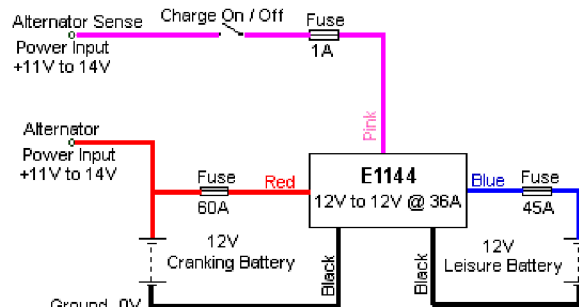

This Battery Charger has been designed using a building block system to obtain the power needed to suit your requirements

This Unit can be provided with a Charging Indicator.

To request a Charging Indicator, please add an "L" to the Part Number, i.e.: E1144-L

IF IN DOUBT, PLEASE CONSULT AN AUTOMOTIVE ELECTRICIAN OR TELEPHONE US ON 01939 235073

EURO MANUFACTURING AND MARKETING LIMITED

Euro Works, 11-13 High Street, Wem, Shropshire SY4 5AA, England.

Tel: +44 (0) 1939 235073

Fax: +44 (0) 1939 235074

Email: sales@eurogroup-gb.com OR sales@battery-management-voltage-converter.com

Web Site: www.eurogroup-gb.com OR www.battery-management-voltage-converter.com